

HDC2004

Test and commissioning unit
for hydraulic drive systems

The moment of truth in the initial commissioning of hydraulic systems and the appurtenant machines and facilities often occurs at the point where machines or other elements fail to behave as envisaged at the planning and design stage. If the delivery date is already history, and contractual penalties are threatening, the result can be an extremely stressful time. Frequently, the only reason is: "We would have tested it earlier, but



PEES

COMPONENTS

Every mechanical engineer knows that drive problems such as jerking, stick slip, guide-element or bearing friction, lack of pressure or lack of flow cannot be "controlled out" – they have to be eliminated on the machine or element itself. This is why the [HDC2004](#) is the answer in enabling performance of pre-commissioning and advance tests on drive systems.

The [HDC2004](#) allows the engineer to move and study his drive arrangements long before the electrical systems and software are completed.

The development target for the [HDC2004](#) was operation of the unit with all valves and pumps equipped with a suitable interface – irrespective of type and manufacturer. In doing this, we were able to exploit the fact that connectors have been standardized for some good time now,





Technical data:

Supply voltage	85 – 260 V	47 – 63 Hz
Max. current take-up at	230 V	0,6 Amp
Max. load rating	at 24 V DC 4,2 Amp	
Measurement, target value (setpoint)	0 – 10 V	± 10 V
		± 10 mA
		± 20 mA
	4 – 20 mA	
	12 mA / ± 8 mA	
Measurement, Sensor		
Current burden	500 Ω	
Voltage	10 kΩ	

In addition to pin assignments, practically all valve manufacturers provide facilities for actuation of valves and pumps using a range of different signals. The HDC2004 therefore features six different target-value (“setpoint”) options.

All setpoints (see “Technical Data”) for current and voltage are “high”. They are therefore suitable for activation of differential input stages. A selector switch for measurement of sensor current or sensor voltage is provided for actual-value measurements. Burden for current measurement is 500 Ohm, with 10 kOhm for voltage measurement.

The HDC2004 also features two outputs for switching-in of two 24V pilot valves, to provide autonomy during commissioning operations. Each of these pilot valves can take up a current of 1.2 A.

The HDC2004 is operated by means of a range of rotary switches, rocker switches and potentiometers.

Operating elements frequently required during operation have been assigned to rocker switches. It is therefore possible, for example, to reverse the drive system quickly, using a pole reverser. A “Fast/Slow” switch permits reduction of speed to 20% with the potentiometer in its extreme position.

Further switches for “Enable” and for the pilot valves permit quick reaction to possible crash situations.

Schematic structure

Figure 1.: The six measuring ranges can be selected using Rotary Switch 2. Selector Switch 1 is used to select the required measuring point. Item 6 permits reduction of speed down to max. 20%. Switch 5 permits setpoint-polarity changing. Switch 8 switches burden to 500 Ohm for current measurement and to 10 kOhm for voltage measurement. Items 7 and 4 are used for switching ENABLE and SIGNAL/GND. Switches 9 and 10

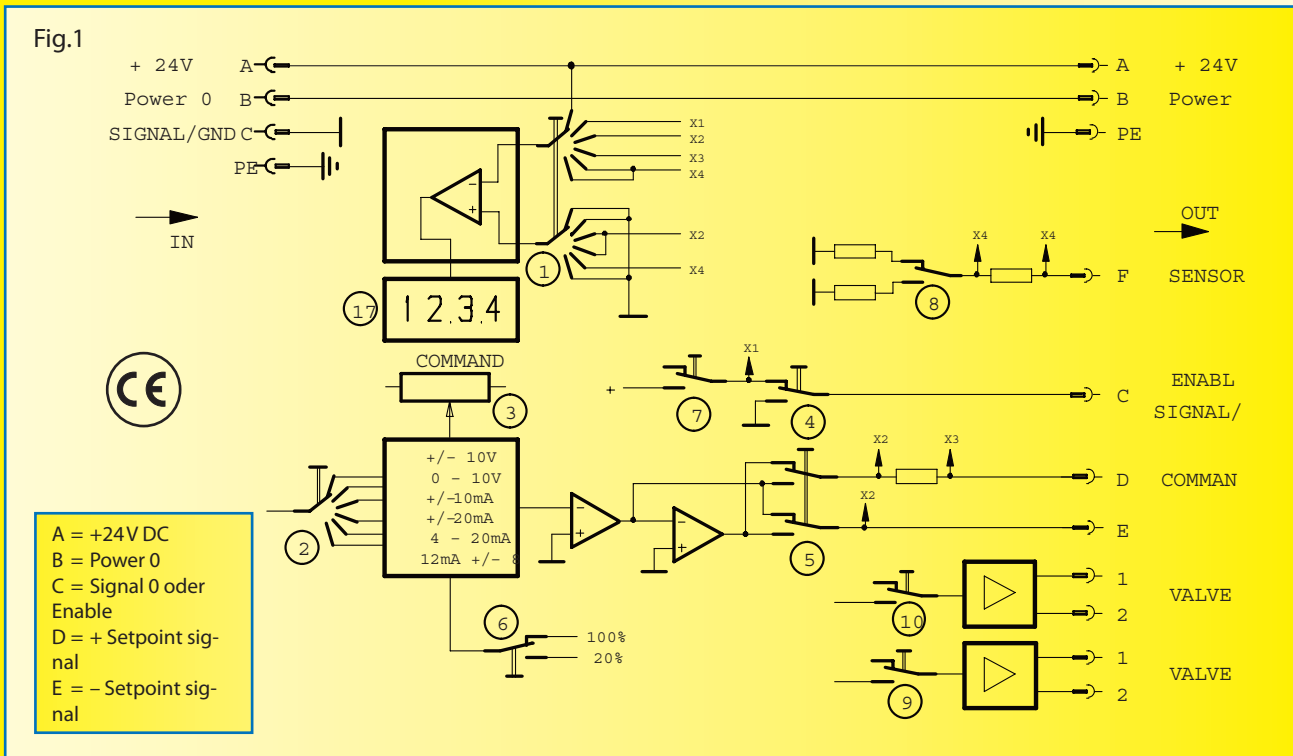

Subject to change without notice | PEES-C | HDC2004 v1 | 03.01.05



Pees Components GmbH
 Paschenfurth 4
 D-47506 Neukirchen-
 Vluynd
 For more information, visit:

Telefon: +49(0)28 45-
 94 96-0
 Telefax: +49(0)28 45-
 www.pees-c.com